

# CATALOGO DE PRODUCTOS



[www.mnarval.com.ar](http://www.mnarval.com.ar)

**Metalúrgica Narval S.R.L.**

[www.mnarval.com.ar](http://www.mnarval.com.ar)



---

# REMACHES

## REMACHES

### ALUMINIO/ACERO CABEZA NORMAL



*STOCK PERMANENTE / También disponible en color negro. Otros colores a pedido*

D1	L	d2	K	W	M	Espesor a remachar		Diámetro agujero		Código Ribot
3,5	6	6	0,9	1,9	30/35	0,5	2,5	3,6	3,75	010101
	8					2,5	4,5			010102
	10					4,5	6,5			010103
	12					6,5	8,5			010104
	14					8,5	10,5			010105
	16					10,5	12,5			010106
	19					12,5	15			010107
	24					16	20			010107.1
	30					20	24			010107.2
4	6	7	1,1	2,15	30/35	1	2	4,1	4,25	010108
	8					2	4			010109
	10					4	6			010110
	12					6	8			010111
	14					8	10			010112
	16					10	12			010113
	19					12	15			010114
	24					16	20			010115
	30					20	24			010115.1
5	8	9	1,5			1	3	5,1	5,25	010116
	10					3	5			010117
	12					5	7			010118
	14					7	9			010119
	16					9	11			010120
	20					11	15			010121
	24					15	19			010122
	28					19	23			010123
	30					23	25			010124
	35					25	30			010124.1
	40					30	35			010124.2
	50					40	45			010124.3
6	8	12	2,2			1	3	6,1	6,25	0101900
	10					3	5			0101901
	12					5	7			0101902
	14					7	9			0101903
	16					9	11			0101904
	19					11	15			0101905
	24									

## REMACHES

### ALUMINIO/ACERO CABEZA NORMAL

STOCK PERMANENTE / También disponible en color negro. Otros colores a pedido

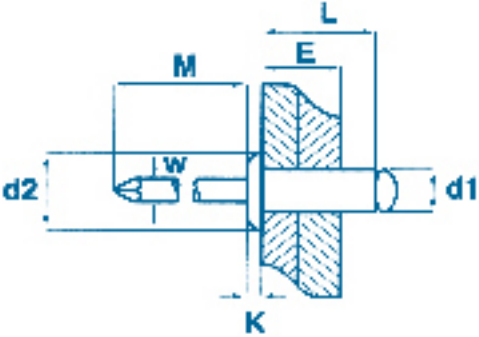
D1	Resist. Cizall.	Resist. Corte	
3,5	75	100	
4	90	40	
5	130	200	
6	200	330	
Aluminio 6063 T "O"			
Acero SAE 1010			
			

## REMACHES

### ALUMINIO/ACERO FLOR



*Mercadería importada - STOCK PERMANENTE*

D1	L	d2	K	W	M	Espesor a remachar	Diámetro agujero	Código Ribot
4	8	8	1	2,2	30	4	4,25	P 4-8
	10					6		P 4-10
	12					8		P 4-12
	14					10		P 4-14
	16					12		P 4-16
	18					14		P 4-18
	20					16		P 4-20
4,8	12	9,5	1,1	2,75	30	7	5	P 5-12
	14					9		P 5-14
	16					11		P 5-16
	18					13		P 5-18
	20					15		P 5-20
	22					17		P 5-22
	25					20		P 5-25
	30					25		P 5-30
	35					30		P 5-35

## REMACHES

### ALUMINIO/ACERO FLOR

Mercadería importada - STOCK PERMANENTE

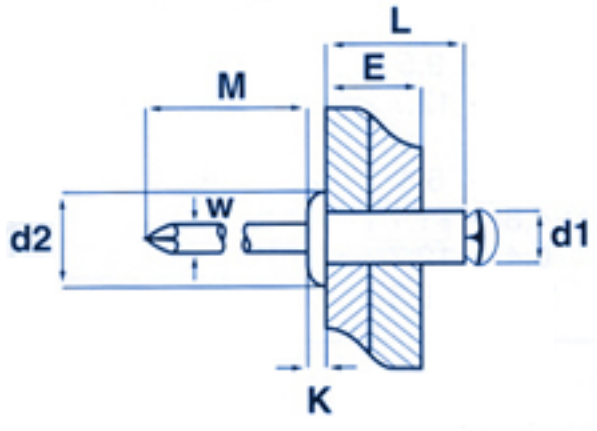
	Resist. Cizall.	Resist. Corte	
D1			
4	150	185	
4,8	200	200	
Aluminio Mg 3,5			
Acero SAE 1010			

## REMACHES

### ALUMINIO/ACERO CABEZA REDONDA

STOCK PERMANENTE

D1	L	d2	K	W	M	Espesor a remachar		Diámetro agujero		Código Ribot
5	8	9	2,6	2,47	30/35	1	3	5,1	5,25	010501
	10					3	5			010502
	12					5	7			010503
	14					7	9			010504
	16					9	11			010505
	20					11	15			010506
	24					15	19			010507

D1	Resist. Cizall.	Resist. Corte	
5	180	250	
			Aluminio 6063 T "0"
			Acero SAE 1010

# Metalúrgica Narval S.R.L.

www.mnarval.com.ar

## REMACHES

### ALUMINIO/ACERO CABEZA AVELLANADA

STOCK PERMANENTE

D1	L	d2	K	W	M	Espesor a remachar		Diámetro agujero		Código Ribot
3,5	6	6,4	1,6	1,85	30/35	0,5	1,5	3,6	3,75	010604
	8					1,5	3,5			010613
	10					3,5	5,5			010601
	12					5,5	7,5			010612
	14					7,5	9,5			010603
4	8	7,5	1,6	2,15	30/35	1	3	4,25		010614
	10					3	5			010605
	12					5	7			010616
	14					7	9			010607
5	10	9,7	2,3	2,45	30/35	1	3	5,25		010609
	12					3	5			010610
	14					5	7			010611
	16					7	9			010612

D1	Resist. Cizall.	Resist. Corte
3,5	75	100
4	90	140
5	130	200

Aluminio 6063 T "O"

Acero SAE 1010

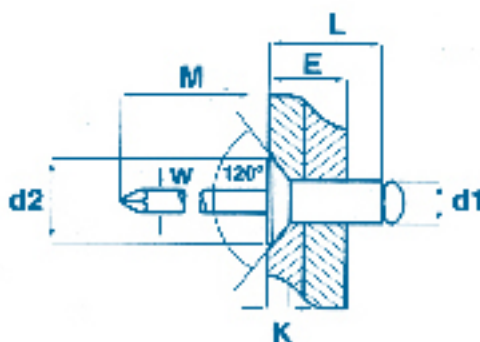



## REMACHES

### COBRE/ACERO CABEZA NORMAL

STOCK PERMANENTE

D1	L	d2	K	W	M	Espesor a remachar		Diámetro agujero	Código Ribot
3,2	6,5	5,7	1	1,85	30/35	0,5	2,5	3,25	010201
	8	2,5				4,5	010202		
	9,5	4,5				6	010203		
4	8	6,7	1,25	2,45	30/35	2,5	4,5	4,25	010204
	10	1,25	2,45	30/35	4,5	6	4,25		010205
5	10	6,7	1,50	3	30/35	3	6	5,25	010206

D1	Resist. Cizall.	Resist. Corte
3,2	80	120

Cobre electrolítico

Acero SAE 1010

# Metalúrgica Narval S.R.L.

www.mnarval.com.ar

## REMACHES

### ACERO/ACERO CABEZA NORMAL

Mercadería importada - STOCK PERMANENTE

D1	L	d2	K	W	M	Espesor a remachar		Diámetro agujero		Código Ribot
3,2	6	6,2	1	2	30/35	0,5	2,5	3,3		0107 S 42
	8					2,5	4,5			0107 S 44
	10					4,5	6,5			0107 S 45
	12					6,5	8,5			0107 S 46
	14					8,5	10,5			0107 S 47
	16					10,5	12,5			0107 S 48
	20					12,5	15			0107 S 49
4	6	7,7	1,25	2,3	30/35	1	2	4,1	4,25	0107 S 52
	8					2	4			0107 S 53
	10					4	6			0107 S 54
	12					6	8			0107 S 56
	14					8	10			0107 S 57
	16					10	12			0107 S 58
	18					12	14			0107 S 59
	20					14	16			0107 S 60
4,8	6	9,2	1,35	3	30/35	0,5	1,5	5		0107 S 62
	8					1,5	3			0107 S 63
	10					3	5			0107 S 64
	12					5	7			0107 S 65
	14					7	9			0107 S 66
	16					9	11			0107 S 68
	18					11	13			0107 S 70
	20					13	16			0107 S 72

## REMACHES

### ACERO/ACERO CABEZA NORMAL

Mercadería importada - STOCK PERMANENTE

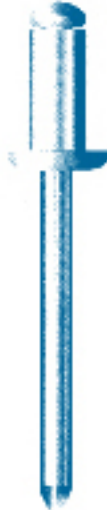
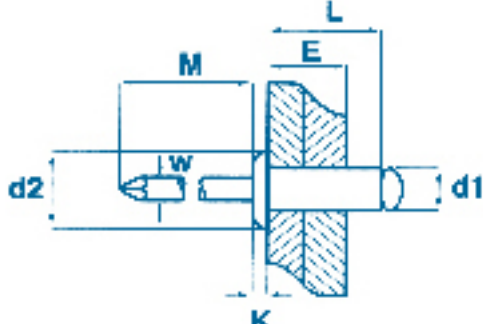
	Resist. Cizall.	Resist. Corte	
D1			
3,2	130	175	
4	190	280	
4,8	290	400	
			
	Acero SAE 1010 cincado		
	Acero SAE 1040 cincado		
			

## REMACHES

### INOXIDABLE/INOXIDABLE CABEZA NORMAL

Mercadería importada - STOCK PERMANENTE

D1	L	d2	K	W	M	Espesor a remachar		Diámetro agujero		Código Ribot
3,2	6	6,25	1	2	30/35	0,5	2,5	3,25	3,3	0108 SS 42
	8					2,5	4,5			0108 SS 44
	10					4,5	6,5			0108 SS 45
	12					6,5	8,5			0108 SS 46
4	6	7,6	1,25	2,5	30/35	1	2	4,1	4,25	0108 SS 51
	8					2	4			0108 SS 52
	10					4	6			0108 SS 54
	12					6	8			0108 SS 56
4,8	8	9,5	1,8	3	30/35	1,5	3	5		0108 SS 63
	10					3	5		0108 SS 64	
	12					5	7		0108 SS 65	
	14					7	9		0108 SS 66	
	16					9	12		0108 SS 68	

D1	Resist. Cizall.	Resist. Corte
3,2	230	270
4	320	390
4,8	430	520

Acero Inoxidable

Acero Inoxidable

## REMACHES

### ALUMINIO/ACERO ESTANCOS

Mercadería importada - STOCK PERMANENTE

D1	L	d2	K	W	M	Espesor a remachar		Diámetro agujero		Código Ribot
3,2	6	6	1,1	1,7	30/35	0,5	2,5	3,25	3,3	0109 AD 41
	8	2,5				3,5	0109 AD 42			
	9,5	3,5				5	0109 AD 43			
	11,2	5				6,5	0109 AD 44			
	12,75	6,5				8	0109 AD 45			
	14	8				10	0109 AD 46			
4	17	10	13	0109 AD 48						
	8	7,75	1,7	2,2	30/35	2,5	3,5	4,1	4,25	0109 AD 52
	9,5	3,5				5	0109 AD 53			
	11,2	5				6,5	0109 AD 54			
12,75	6,5	8				0109 AD 55				
4,8	8,4	9,45	1,9	2,65	30/35	0,5	3,5	5	0109 AD 62	
	12	5				6,5	0109 AD 64			
	13,1	6,5				8	0109 AD 65			
	15,1	8				9,5	0109 AD 66			
	18,3	11				13	0109 AD 68			
	25	15				20	0109 AD 69			

D1	Resist. Cizall.	Resist. Corte
3,2	110	140
4	180	250
4,8	240	340

Aluminio 6063 T "O"

Acero SAE 1010

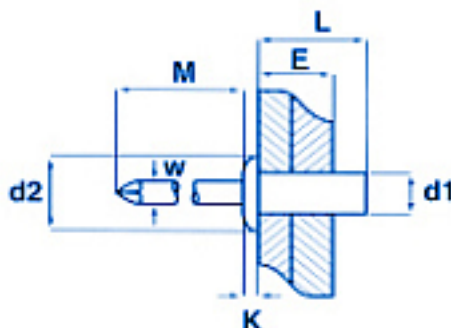

# Metalúrgica Narval S.R.L.

www.mnarval.com.ar

## REMACHES

ALUMINIO/ACERO CABEZA ALA ANCHA  
ALUMINIO/ACERO CABEZA EXTRA LARGA\*

STOCK PERMANENTE

D1	L	d2	K	W	M	Espesor a remachar		Diámetro agujero		Código Ribot
3,5	10	9	1,24	1,9	30/35	4,5	6,5	3,6	3,75	010409
	12					6,5	8,5	010410		
	14					8,5	10,5	010411		
4	8	11	1,4	2,15	30/35	2	4	4,1	4,25	010405
	10					4	6	010406		
	12					6	8	010407		
	14					8	10	010408		
5	12	13	1,8	2,45	30/35	5	7	5,1	5,25	010401
	14					7	9	010402		
	16					9	11	010403		
	20					11	15	010404		
	4,8*					12	15,8	15,8	2,6	30/35
	14					7	9		A/A 514	
	16					9	11		A/A 516	
	21					11	16		A/A 521	
	27					17	22		A/A 527	

D1	Resist. Cizall.	Resist. Corte
3,5	75	100
4	90	140
4,8*	150	220
5	130	200

Aluminio 6063 T "O"

Acero SAE 1010

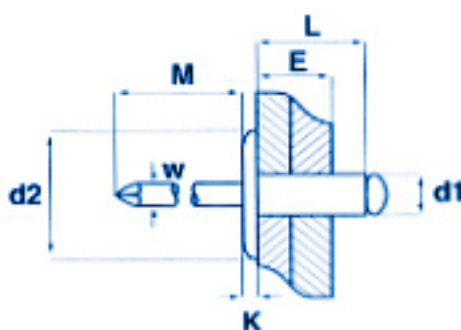

## REMACHES

### ALUMINIO/ACERO MULTIGRIP



Mercadería importada - STOCK LIMITADO

D1	L	d2	K	W	M	Espesor a remachar		Diámetro agujero		Código Ribot
3,2	6,8	6,2	1,1	1,8	30	0,8	3,4	3,25		U 3,2-6
	8					4,8			U 3,2-8	
	9,5					6,4			U 3,2-9	
	11,1					7,9			U 3,2-11	
4	6,8	8,2	1,4	2,2	30	0,5	3,2	4,1	4,25	U 4-6
	9,5					6,4			U 4-9	
	12,7					9,5			U 4-12	
	16,9					12,7			U 4-16	
4,8	10,3	9,2	1,8	2,75	30	1,6	6,4	5		U 5-10
	15,1					11,1			U 5-15	
	16,9					12,7			U 5-16	
	24,8					19,8			U 5-24	

D1	Resist. Cizall.	Resist. Corte
3,2	75	104
4	115	170
4,8	160	240

Aluminio Mg 3,5

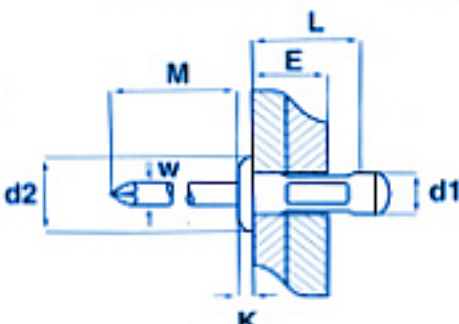
Acero SAE 1010

## REMACHES

### ACERO/ACERO MULTIGRIP

Mercadería importada - STOCK LIMITADO

D1	L	d2	K	W	M	Espesor a remachar		Diámetro agujero	Código Ribot
3,2	8	5,3	1	1,8	30	0,5	4,5	3,3	U 3,2-8
	9,5					1,5	6,5		U 3,2-9
	11,1					4	7,5		U 3,2-11
	12,7					5	9,5		U 3,2-13
4	9,5	6,2	1,35	2,2	30	1,2	6,5	4,25	U 4-9
	11,1					3,2	7,5		U 4-11
	12,7					4	9,5		U 4-13
	15,1					6,5	11		U 4-15
	16,9					6,5	13		U 4-17
4,8	10,3	8,6	1,65	2,75	30	1,25	6,5	5	U 5-10
	15,1					4,8	11		U 5-15
	16,9					6,4	12,5		U 5-17
	24,8					12,5	19,5		U 5-25

D1	Resist. Cizall.	Resist. Corte
3,2	75	104
4	115	170
4,8	160	240

Acero SAE 1010

Acero SAE 1010



## REMACHES

### ALUMINIO/ACERO TREBOL CABEZA NORMAL

Mercadería importada - STOCK LIMITADO

D1	L	d2	K	W	M	Espesor a remachar		Diámetro agujero		Código Ribot
4	13,6	8	1,4	2,4	30	1	3	4.25		T 4-13
	1					7			T 4-18	
4,8	15,3	8,8	1,5	2,9	30	1	3	5	5,25	T 5-15
	1					9			T 5-20	
	4					12			T 5-24	

D1	Resist. Cizall.	Resist. Corte
4	70	120
4,8	110	140

Aluminio 6063 T "O"

Acero SAE 1010

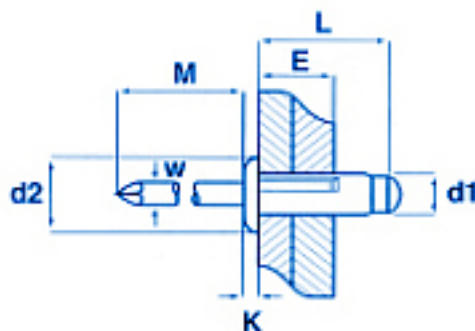

## REMACHES

### ALUMINIO/ACERO RANURADO CABEZA NORMAL

Mercadería importada - STOCK LIMITADO

D1	L	d2	K	W	M	Espesor a remachar	Diámetro agujero	Código Ribot
3,2	10	6,5	0,8	1,8	30	6	3,5	R 3,2-10
4	8	8	1	2,2	30	4	4,3	R 4-8
	12					6		R 4-12
	16					8		R 4-16
4,8	10	9,5	1,1	2,75	30	6	5,1	R 5-10
	14					10		R 5-14
	18					13		R 5-18
	21					15		R 5-21
	24					20		R 5-24

D1	Resist. Cizall.	Resist. Corte
3,2	60	80
4	80	100
4,8	110	140

Aluminio 6063 T "O"

Acero SAE 1010

